

TECHNICAL SPECIFICATION

Ecoscape UK Forma[®] Composite Panel Cladding Board

Tech Specs

Forma 3600mm

Forma 4800mm

Colour



Midnight, Argent,
Flint, Silver Birch,
Spiced Oak,
Havana, Industry



Midnight, Argent,
Flint, Silver Birch,
Spiced Oak,
Havana,

Finish

Single Sided
Wood Grain



Single Sided
Wood Grain



Size & Weight

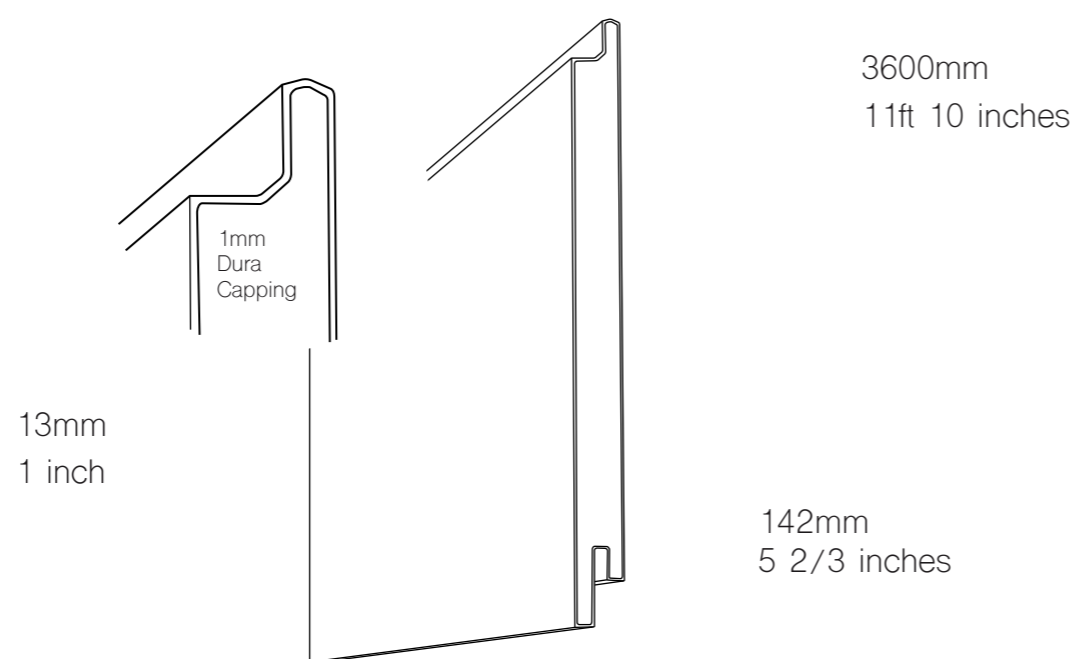

Weight: 8 kg per length
2.23kg per m

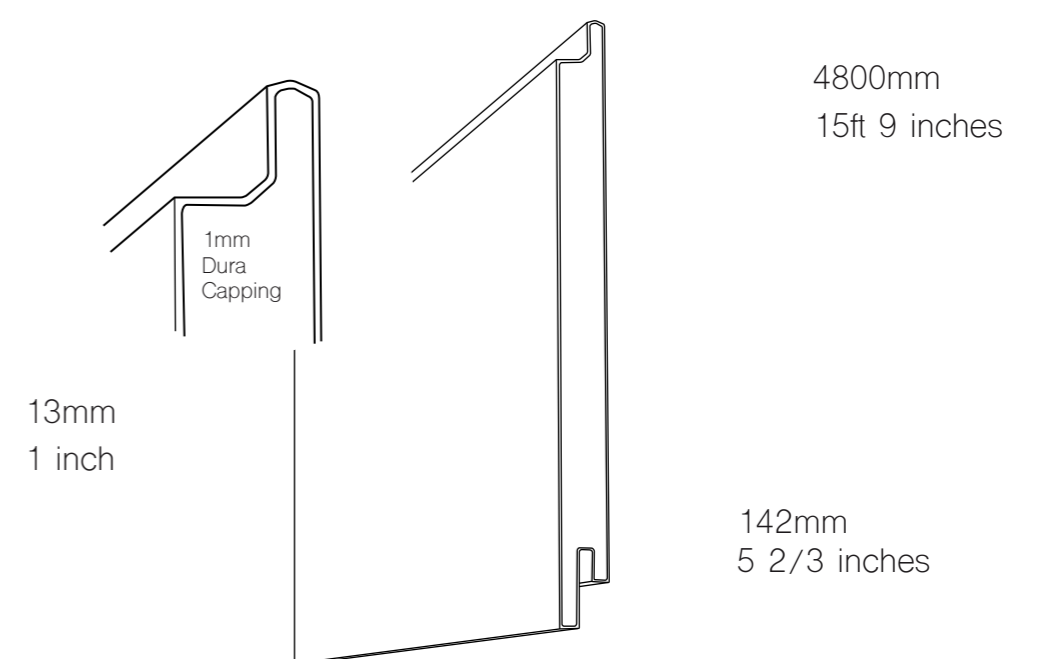

Weight: 10.70 kg per
length 2.23kg per m

Property	Test Method	Test Results	Notes
Abrasion Resistance	ASTM D4060-10	33mg (1000 cycles)	
Brinell Hardness	EN15534	8.2N/mm ²	
Boiling Test	EN15534	Water absorption in weight: 0.49%	
Bond Strength	EN319	Average Bond strength > 2.3MPa No obvious abruption and damage after test	
Coefficient Linear Thermal Expansion	ASTM D696	35.6x10 ⁻⁸ mm/mmc	
	EN15534	34.0x10 ⁻⁶ K ⁻¹	
Content of Pentachlorophenol	CE (EN14041(2004))	2.99ppm	
Degree of Chalking	EN15534	Rating 0, no chalking	
Fire Resistance	BS476-7	Class 2	On Request please advise when speaking to seller
	EN13501-1, EN ISO9239-1, EN ISO11925-2	Reaction to fire classification B ^f -S ¹	
	EN ISO9239-1, EN ISO11925-2	Classification B ^f -S ¹	
	GB8624, GB11785 GB8626, GB20286	Reaction to fire classification GB8624B1(B-S1, T1)	
	ASTM E84	Flame Spread Index (FSI): 85 Smoke Developed Index (SDI): 300	
Formaldehyde Content	EN717-1	Non Detected	
	ASTM D6007-14	Non Detected	
Heavy Metal Content	EPA3052	Sb:ND, As:ND, Se:ND, Sn:ND	
Heat Reversion	EN15534 EN 479	Test temperature: 100c: 017%	

Property	Test Method	Test Results	Notes
Heat Build-up	EN15534	$\Delta t = -2.7c$	
Lead Content Test	EUNo.628/2015	Non Detectable	
Mould Resistance	ASTM G21	Rating: 0	
Moisture Content	EN15534, EN322	0.83%	
Neutral Salt Spray Test	ASTM B117-2011	After 200 hour test, there was no visible change appeared on the surface: Front surface: $\Delta E^* = 1.22$, grey scale; 4-5 Back surface: $\Delta E^* = 1.06$ grey scale; 4-5	
	EN15534 ISO9227	$\Delta E^* = 1.42$, grey scale; 4 (Exposure 96h)	
pb, cd, hg, cr ⁵⁺	RoHs-IEC62321	pb:ND, cd:ND, hg:ND, cr ⁵⁺ :ND	
Resistance to Scratch Test	ISO4586-2	Rate 2	
Resistance to Indentation	EN15534	Apply 2000N load Brinell hardness: 72Mpa, Rate of elastic recovery 65%	
Resistance to Artificial Weathering	EN15534 ISO4892-2	After 2000h exposure $\Delta E^* = 1.09$, grey scale=4-5	
Rockwell Hardness	ASTM D785	78.7R	
Swelling & Water Absorption (24 hours submersion)	EN15534	1 Swelling: 0.06% in thickness, 0.03% in width, 0.03% in length 2 Water absorption: 0.49%	
Swelling & Water Absorption (28 days submersion)	EN15534	1 Swelling: 0.78% in thickness, 0.07% in width, 0.12% in length 2 Water absorption: 1.66%	
SRI Testing	ASTM C1549 ASTM C1371 ASTM E1980	19	

Property	Test Method	Test Results	Notes
Surface Bond Quality	EN319	>2.08Mpa	
Thermal Resistance	ASTM C518-2010	Thermal Conductivity: 0.3589W/(m-k) Thermal Resistance: 0.0830(m ² -k)/W	
Thermal Conductivity	CE (EN14041(2004))	0.19738W/(m-k)	
UV Weathering Test	ASTM G154	After 3000 hour test grey scale3, $\Delta E^*=3.56$	
Uplift Resistance	ICC-ES AC174 ASTM E330	Average ultimate load ≥ 427 psf	
VOC & TVOC	ASTM D5116-11	Non Detectable	
Water absorption	ASTM D1037	Water absorption (24h): 0.12%	
Installation Span	Manufacturer Specification	500mm on center	